

# Jürgen Haibles EDP Wasp VCF clone

If you're looking for a unique sound build this one. Besides the PoLiVoKs this is my favourite filter!

Jürgen Haible says: It sounds considerably different than the ordinary SEM-type state variable filter. The maximum Q is lower on the Wasp version. And there is an additional distortion coming from the CMOS inverter nonlinearities. This distortion is gradually increasing with input level, and you can slightly hear it way before the circuit actually clips. The CMOS inverters seem to be the dominant source of distortion; the CA3080 input dividers are rather on the save side.

MODIFICATIONS: two schottky diodes BAT85 added for CMOS protection.

C1, C6	220n
C2	68pF
C3	220n
C4, C5, C8, C9	1n
C7, C11	100n
C10, C12	10uF (elec)
D1, D2, D3	1N4148
D4, D5	BAT85 Scottky
J1	in
J2	cv
J3	out
P1	50k gain
P2	10k log cutoff
P3	47k ressonance
R1, R2, R3, R9, R10, R14, R15, R23, R27	33k
R4, R5, R6, R21, R22, R26	100k
R7, R12, R25	51k
R8, R13, R17, R18, R19	1k
R11, R16	4.7k
R20	10k
R24	1M
R28	470k
U1	CD4069
U2, U3	CA3080
U4	LM7805
W1	NP
W2	HP
W3	LP
W4	BP
W5	dist in
W6	dist out
W7	dc

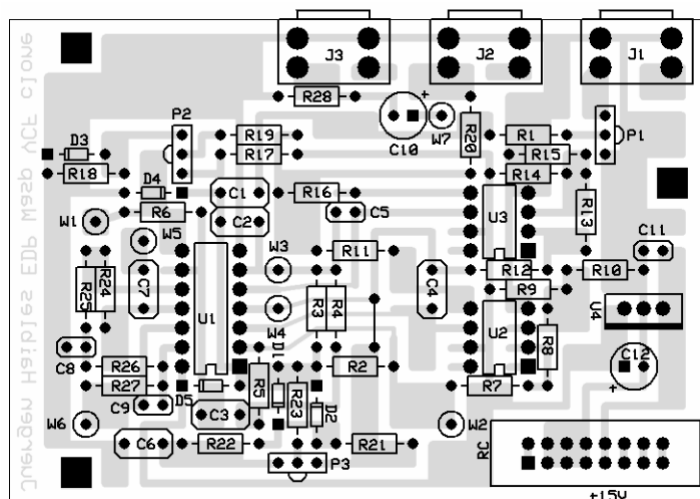
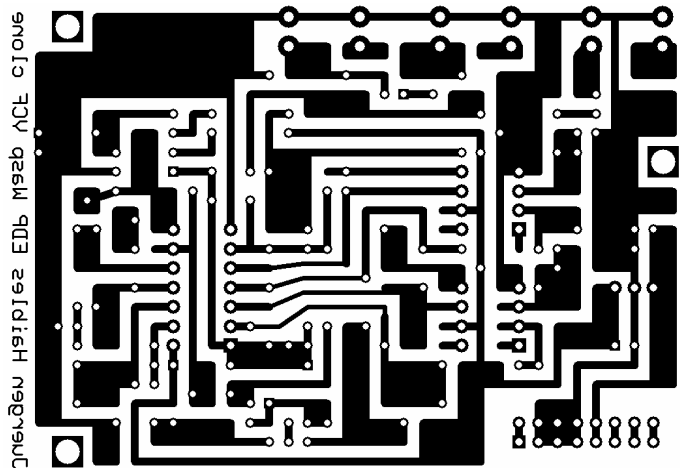

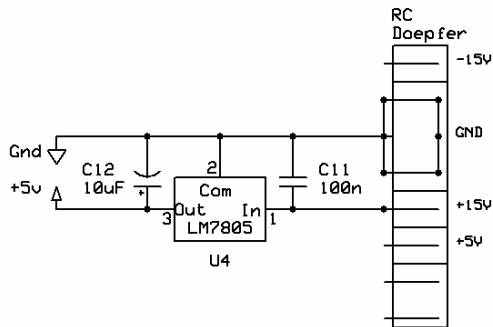
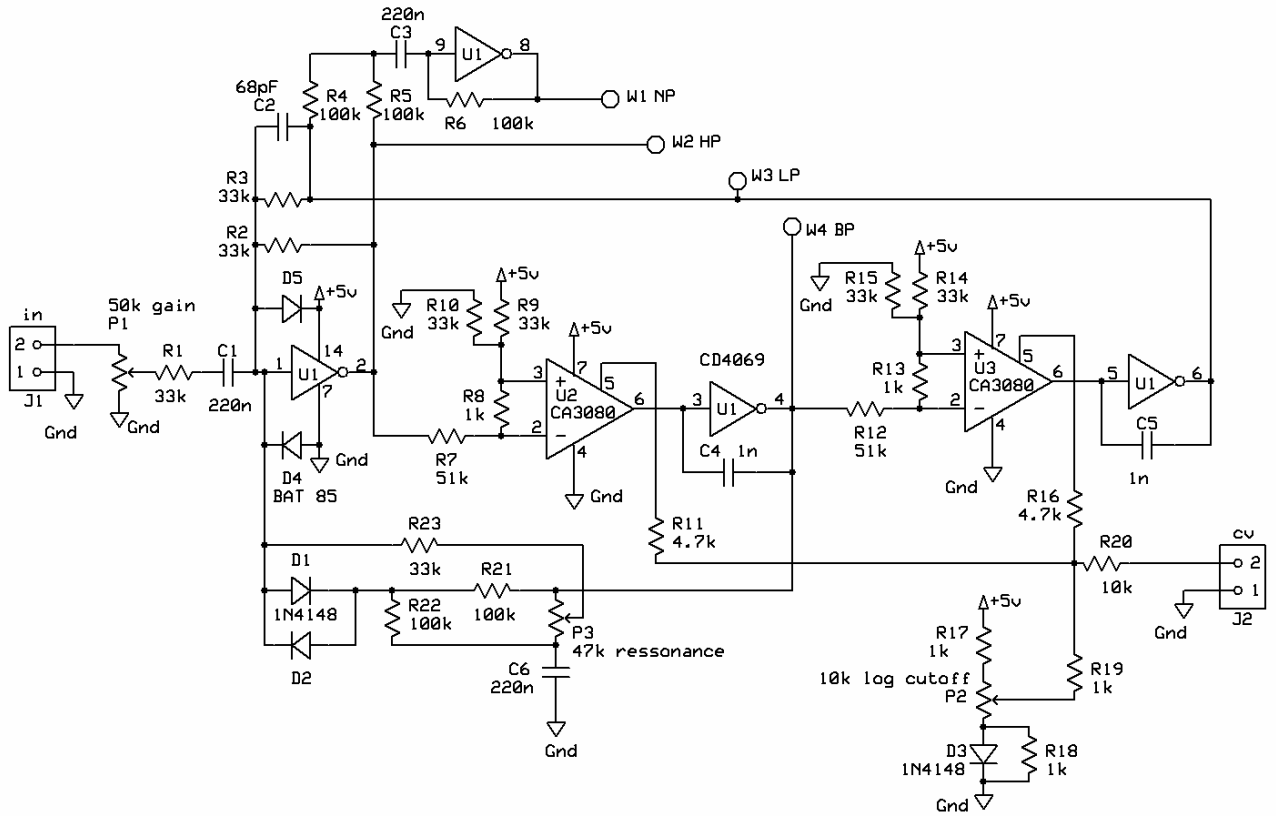
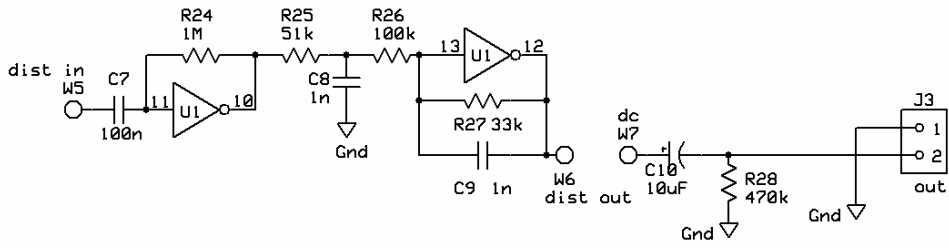

EDP Wasp YCF (+5V powered)

Juergen Haible

Rev 1.1

12 DEC 2006

Matthias Herrmann

# Front panel wiring

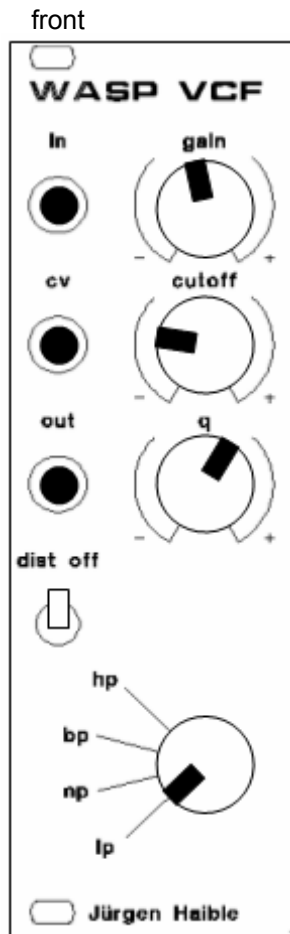

reverse

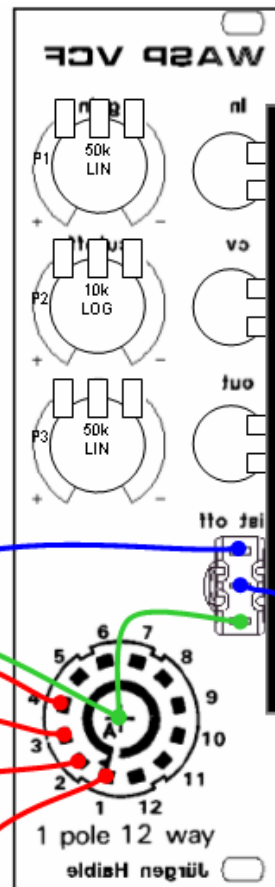

How to connect the pots:

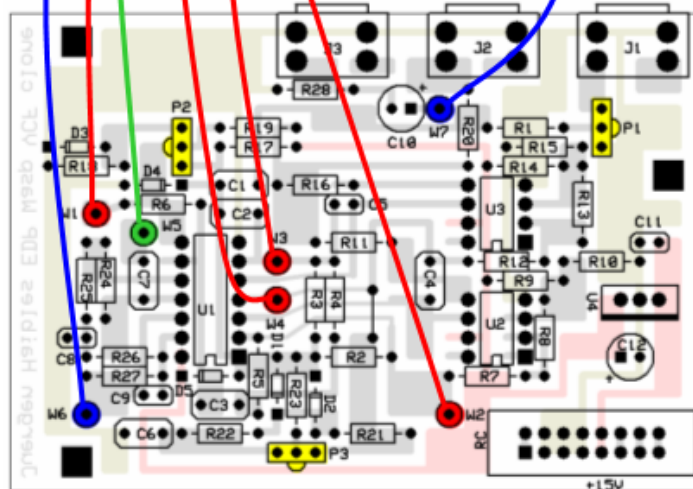
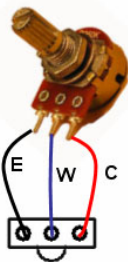

PRESS'N'PEEL BLUE

