

# Attack - Release Envelope Generator

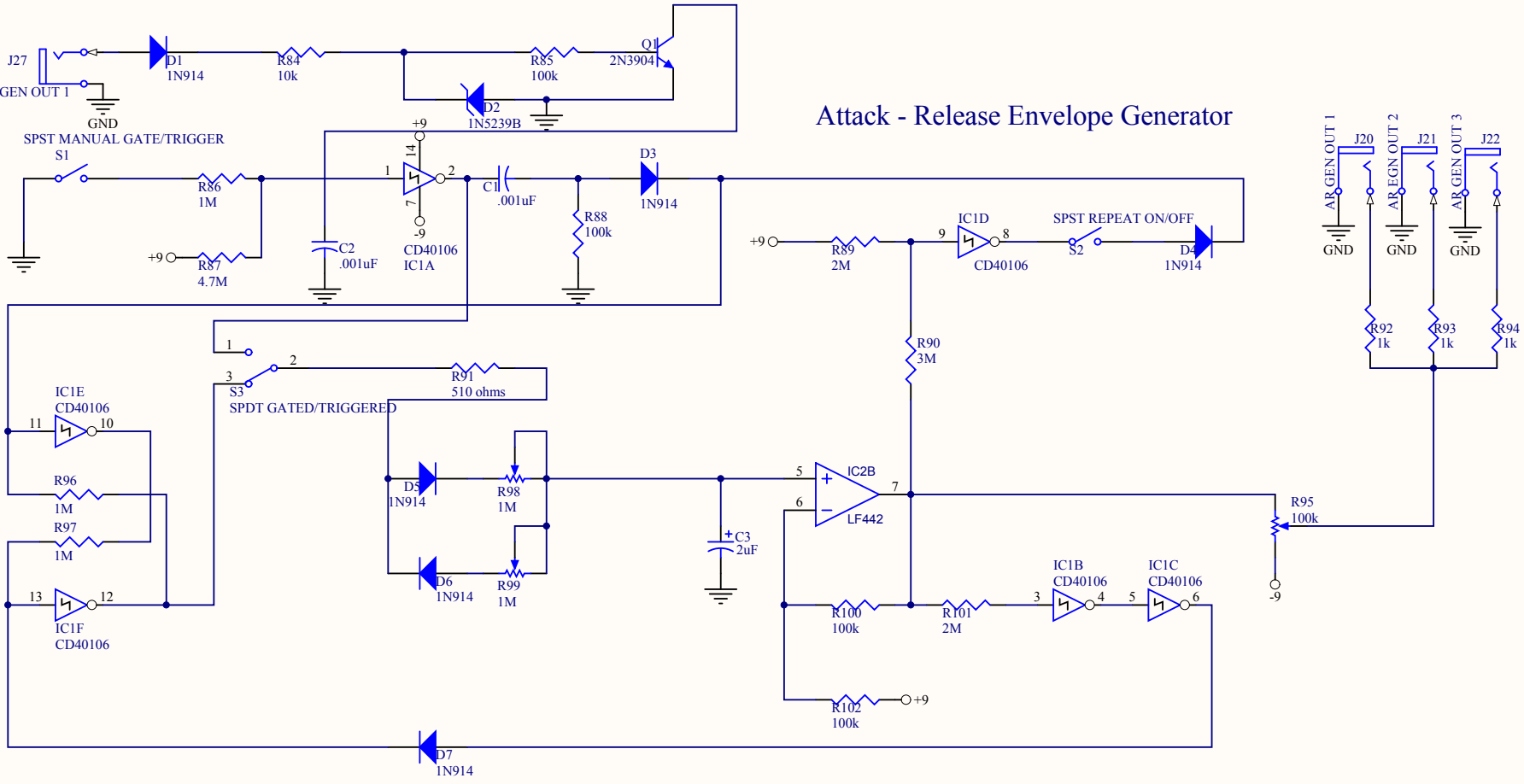

Title		
Size	Number	Revision
A4		
Date:	6/11/2015	Sheet of
File:	C:\Users\...\ADSR generatorwithCV.V2.SchDown By:	

### LFO (Low Frequency Oscillator)

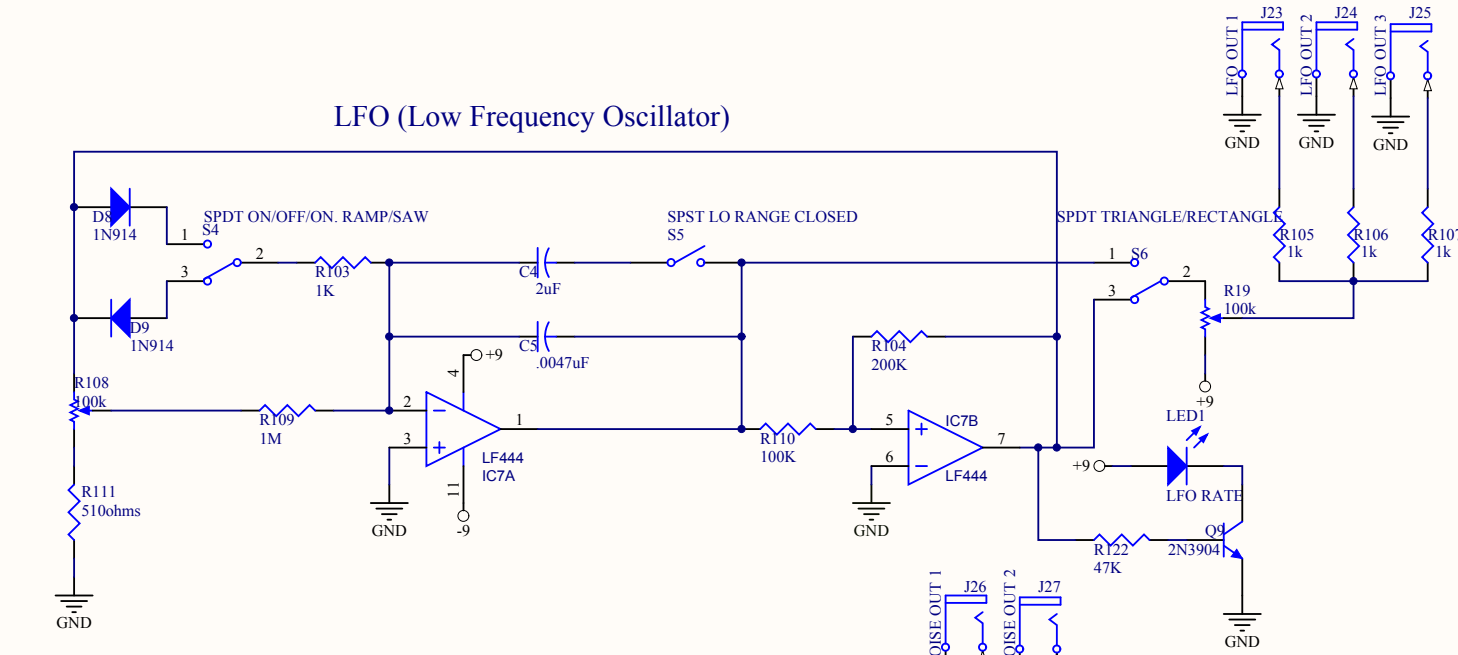

### Noise Source

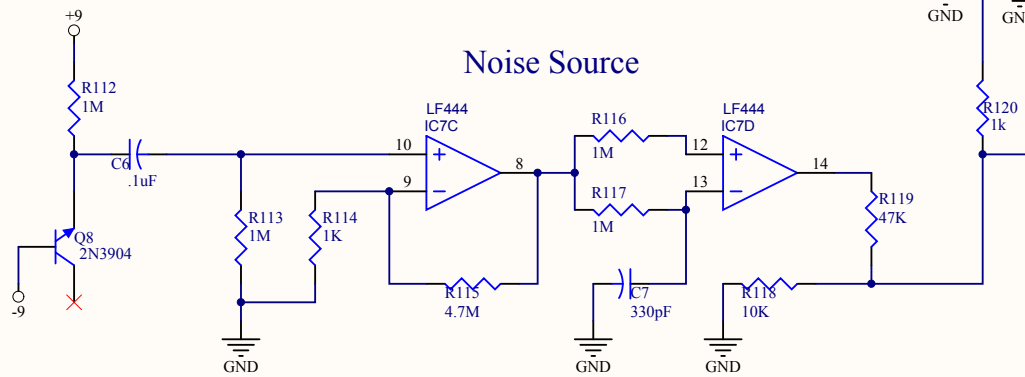

### +/- 9 Volt Battery Power Supply

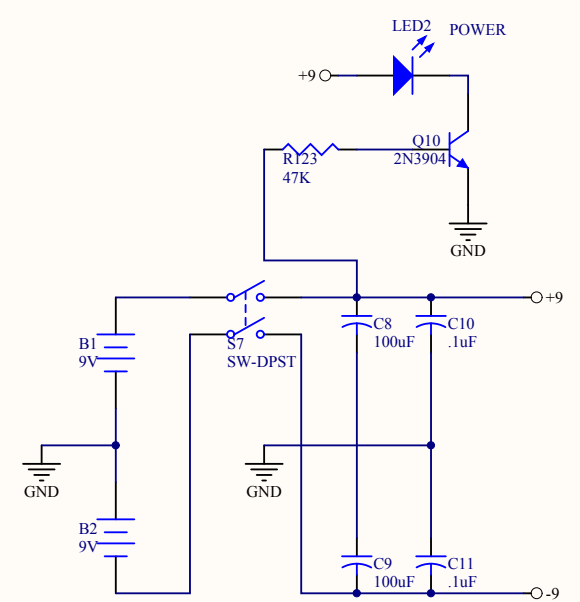

Title		
Size	Number	Revision
A4		
Date:	6/11/2015	Sheet of
File:	C:\Users\ALFO NG POWERwithCV.V2.Sch	Drawn By:

### VCOs (Voltage Controlled Oscillators) Rev 002

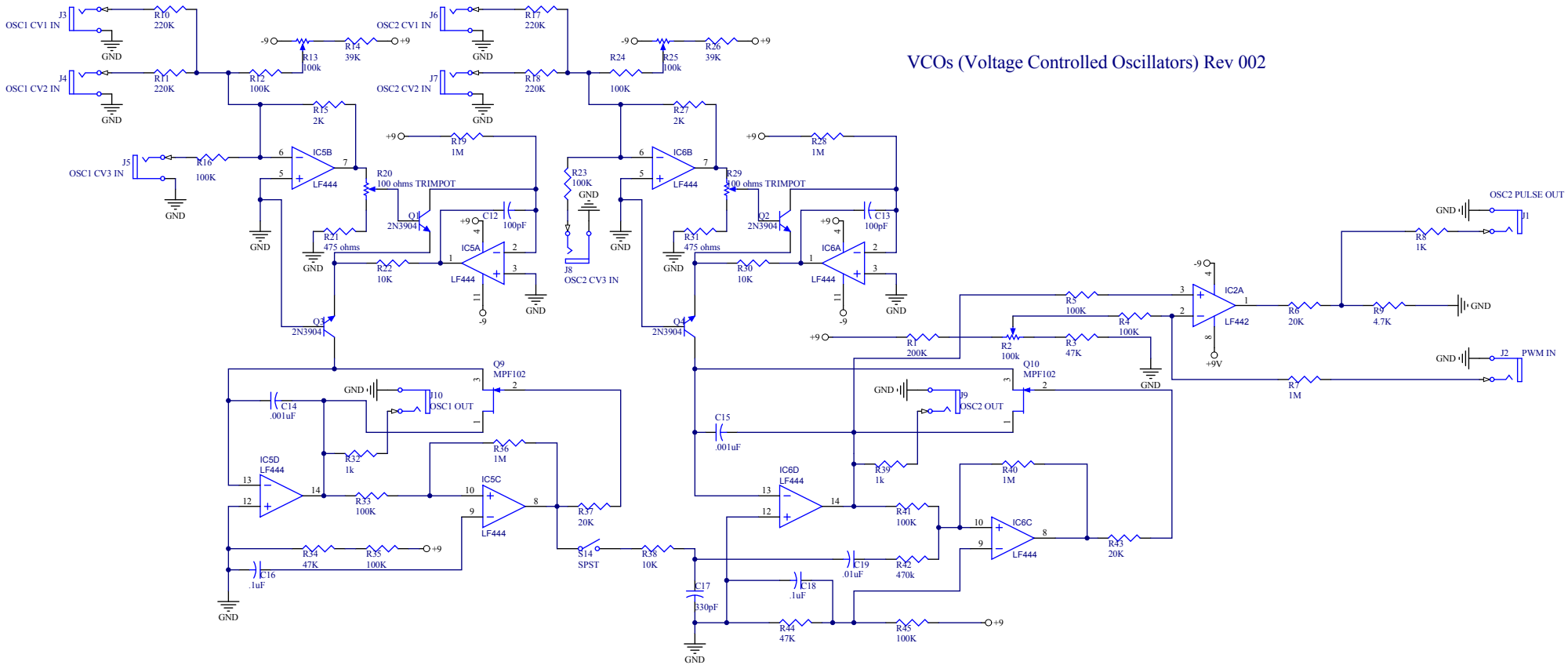

Title		
Size	Number	Revision
A3		
Date:	6/11/2015	Sheet of
File:	C:\Users\...VCOWithCV.V2.SchDoc	Drawn By:

### VCA (Voltage Controlled Amplifier)

### VCF (Voltage Controlled Filter)

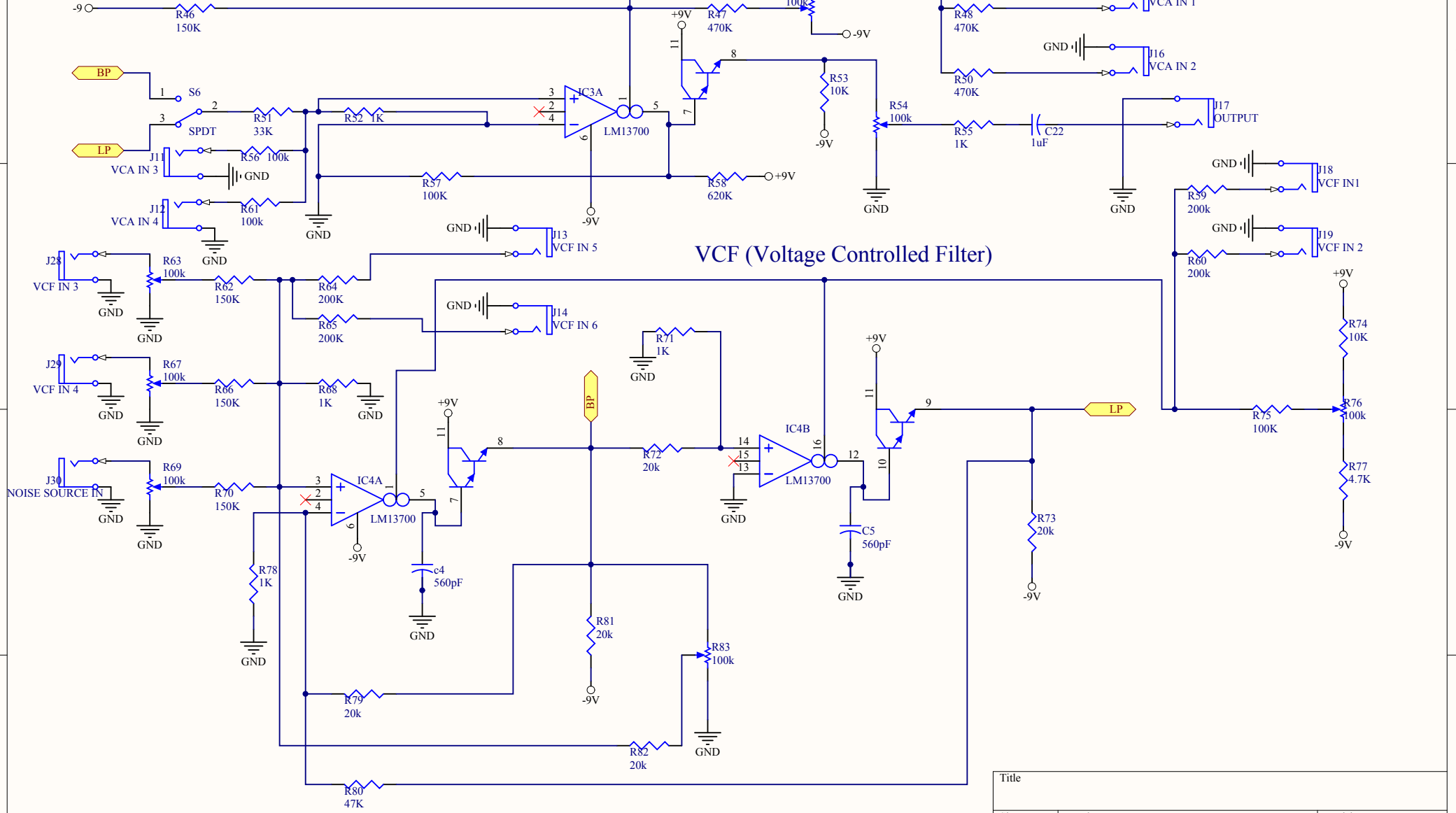

Title		
Size	Number	Revision
A4		
Date:	6/11/2015	Sheet of
File:	C:\Users\...\VCSVfwithCV.V2.SchDoc	Drawn By:

