

⬆ = +5V
⬇ = -6.5V

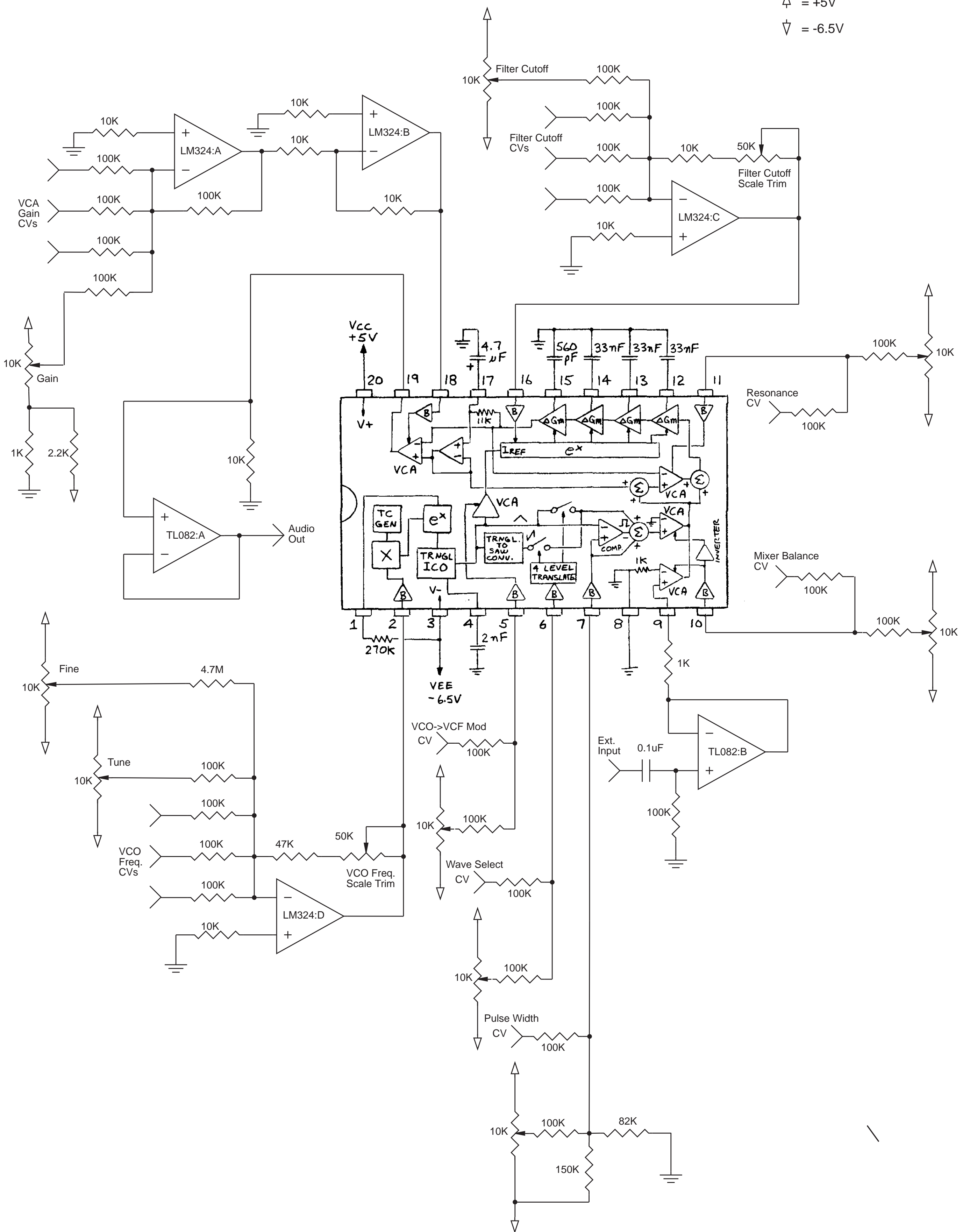

CEM3394 Interface

Description:

Allows the use of a Curtis 3394 synth chip in a modular-type system. See the CEM3394 datasheet for details.

Engineering notes:

Be sure to use LM324 or equivalent op-amps where specified, especially if you are using this circuit with modules that can output a wide voltage range. LM324s are well-behaved when the inputs get close to the rails. A TL084 will invert on you.

Mods:

You could probably get away with ditching the active mixer on the VCA CV input. This will save you 2 op-amps.